

Item description/product images



Description

Material:

Tool steel or 1.4305 stainless steel.

Version:

Steel hardened and ground.

Stainless steel ground and kolsterised.

Note:

Ball end locating pins are specially designed to ease the locating process. The tendency to jam, caused by the locating hole not being at right angles to the pin or by the pushing force not being parallel to the pin axis, is minimized by the ball-end form. (See the illustration 1 by 03108 Form B)

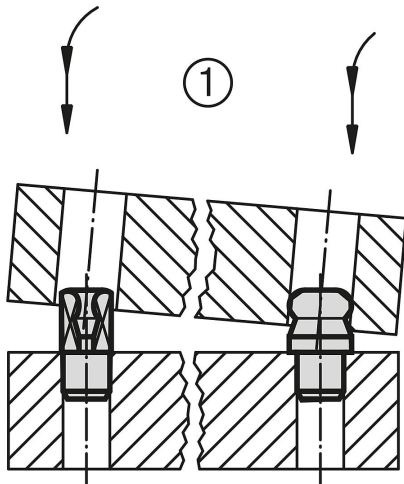

Drawings

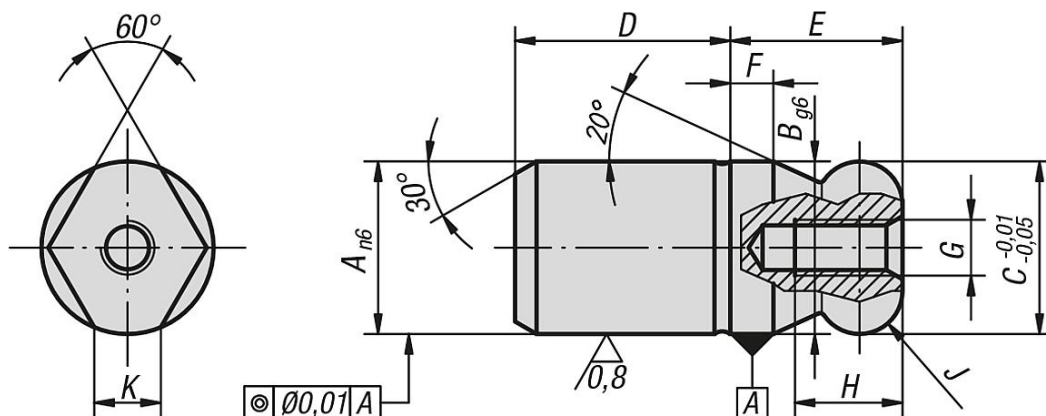

Overview of items

Order No. tool steel	Order No. stainless steel	A	B	C	D	E	F	G	H	J	K
03107-052	03107-5052	5	5	5	6	5	2	M2,5	4,5	R 1	1,5
03107-062	03107-5062	6	6	6	8	6	2	M3	5	R 1	1,8
03107-082	03107-5082	8	8	8	10	8	2	M3	6	R 2	1,9
03107-102	03107-5102	10	10	10	13	10	2,5	M3	6	R 2,5	2,5
03107-122	03107-5122	12	12	12	15	12	3	M4	8	R 3	2,5
03107-142	03107-5142	14	14	14	17	14	3,5	M4	8	R 3,5	3,9
03107-162	03107-5162	16	16	16	20	16	4	M5	10	R 4	4,3
03107-202	03107-5202	20	20	20	25	20	5	M5	10	R 5	5
03107-252	-	25	25	25	25	25	6	M5	10	R 6	5,6

## Overview of items

Order No. tool steel	Order No. stainless steel	A	B	C	D	E	F	G	H	J	K
03107-302	-	30	30	30	30	30	8	M6	12	R 8	8,8
03107-402	-	40	40	40	40	40	10	M6	12	R 10	12,8
03107-502	-	50	50	50	50	50	12	M6	12	R 12	16,7