

Dipl.-Ing. Herwarth Reich GmbH

D2C
Designed to Customer

MULTI MONT OCTA

Torsionally flexible flywheel coupling
for internal combustion engines

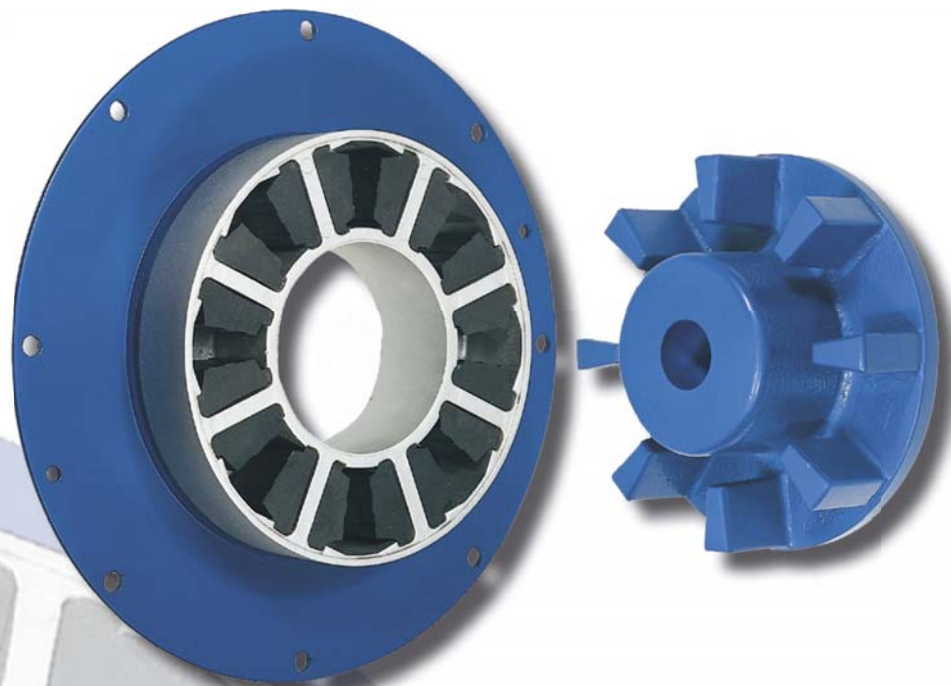

Your drive is our strength. Your strength is our drive.



Contents

	Page
General technical description	3
Technical details	4
Selection of the proper coupling size	4
Dimension tables	5
Materials	6
Mounting instructions	6
Typical installations	7
Technical note	7
Safety precautions	7

D2C – Designed to Customer



The principle of Designed to Customer describes the recipe for success of REICH-KUPPLUNGEN: Utilizing our product knowledge, our customers are supplied with couplings which are developed and tailor-made to their specific requirements. The designs are mainly based on modular components to provide effective and efficient customer solutions. The unique form of close cooperation with our partners includes consultation, design, calculation, manufacture and integration into existing environments. Adapting our manufacturing to customer-specific production and utilizing global logistics concepts provides better after sales service - worldwide. This customer-oriented concept applies to both standard products and production in small batch sizes.

The company policy of REICH-KUPPLUNGEN embraces, first and foremost, principles such as customer satisfaction, flexibility, quality, prompt delivery and adaptability to the requirements of our customers.

REICH-KUPPLUNGEN supplies not only a coupling, but a solution: Designed to Customer.

Edition February 2013

Proprietary notice pursuant to ISO 16016 to be observed:

The present MULTI MONT edition renders parts of the previous MULTI MONT catalogues obsolete. All dimensions in millimeters.

The reproduction, distribution and utilization of this document as well as the communication of its contents to others without explicit authorization is prohibited. Offenders will be held liable for the payment of damages. All rights reserved in the event of the grant of a patent, utility model or design. © REICH-KUPPLUNGEN

We reserve the right to change dimensions and/or design details without prior notice.

General technical description

The MULTI MONT OCTA flywheel coupling is designed specifically as a torsionally flexible drive coupling for units with internal combustion engines. It is used to dampen torsional vibrations and to compensate for misalignments.

The series comprises 6 different sizes covering a nominal torque range from 300 to 20 000 Nm.

MULTI MONT OCTA flywheel couplings give positive torque transmission with rubber elements under compression. These rubber elements can be supplied in different Shore hardnesses for optimizing the torsional vibration range. Any occurring torsional vibrations and peak torques are dampened and absorbed efficiently.

Overload protection

As the coupling flange is produced as a composite casting, a positive connection serving as a rated break point is provided between the steel plate flange and the cast-on aluminium coupling part. Power transmission will thus be interrupted as soon as the coupling is overloaded far beyond the permissible maximum torque so that essential system components are protected against potential damage.

Type approvals by a number of leading classification societies are at hand.

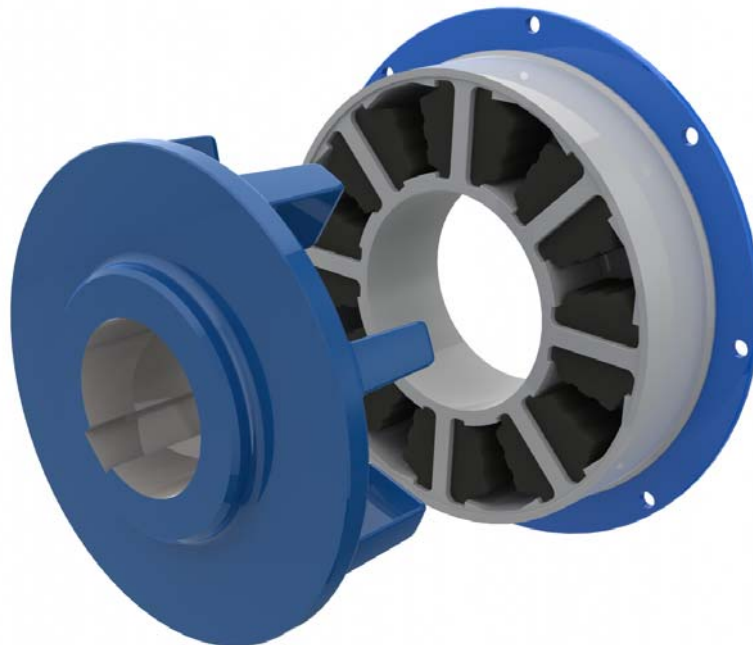

Salient features and advantages of the MULTI MONT OCTA flywheel coupling

- Efficient torsional vibration and peak torque dampening and absorbing capability
- Ease of assembly thanks to the plug-in type design
- Compensation of axial, radial and angular misalignments
- Coupling hub of spheroidal cast iron as a standard
- Fail safe design combined with a high load carrying capability, nevertheless with protection against overload breakage by means of the existing rated break point
- Simple, compact and thus low-cost coupling design

Technical details

Rubber element versions: WP = 55° Shore A; NP = 65° Shore A; SP = 75° Shore A

Coupling size	Element version	T _{KN} Nm	T _{Kmax} Nm	T _{KW} (10 Hz) Nm	Dynamic torsional stiffness ¹⁾ C _{T dyn} [Nm/rad]				Relative damping	Max. Speed rpm
					0.25 T _{KN}	0.5 T _{KN}	0.75 T _{KN}	1.0 T _{KN}		
MMO 65	WP	340	1300	170	5250	5750	8000	10000	0.8 - 0.9	5500
	NP	430	1500	200	6500	9100	12500	15700	0.9 - 1.0	
	SP	650	1940	325	8750	10600	18000	25500	1.0 - 1.1	
MMO-125	WP	600	2200	300	11000	11500	15000	18500	0.8 - 0.9	4900
	NP	840	2900	390	17500	21000	29400	38800	0.9 - 1.0	
	SP	1250	3750	625	20800	34200	45700	60000	1.0 - 1.1	
MMO-260	WP	1300	4800	650	23500	31000	35000	41000	0.8 - 0.9	4200
	NP	1700	5900	810	30000	36000	47500	59000	0.9 - 1.0	
	SP	2600	7800	1300	62000	71500	95000	110000	1.0 - 1.1	
MMO-500	WP	2500	9000	1250	54000	56000	93000	115000	0.8 - 0.9	3500
	NP	3300	11500	1600	69000	80000	115000	152000	0.9 - 1.0	
	SP	5000	15000	2500	103000	120000	183000	214000	1.0 - 1.1	
MMO-1100	WP	5600	22000	2800	80000	90000	156000	228000	0.8 - 0.9	2600
	NP	7300	25000	3100	115000	154000	190000	260000	0.9 - 1.0	
	SP	11000	33000	5000	160000	200000	300000	390000	1.0 - 1.1	
MMO-2000	WP	10000	40000	5000	160000	180000	260000	340000	0.8 - 0.9	2400
	NP	13000	45000	6300	248000	300000	455000	600000	0.9 - 1.0	
	SP	20000	60000	10000	332000	460000	620000	840000	1.0 - 1.1	

¹⁾ The given dynamic torsional stiffnesses allow for a temperature of +60 °C to +80 °C at the coupling.

Selection of the proper coupling size

The coupling size to be used in conjunction with internal combustion engines shall be dimensioned and selected with a view to torsional vibration. For a rough estimate based on the engine drive torque T_{AN}, a general safety factor of S = 1.3 - 1.5 should be allowed for.

The following requirements shall be satisfied for the proper selection of the coupling size:

- Calculate the driving torque T_{AN}
Given a driving power P_{AN} and a coupling speed n_{AN}, the driving torque is calculated as follows

The nominal torque capacity T_{KN} of the coupling shall be at least equal to the max. drive torque T_{AN} while taking the temperature factor S_t into account

The temperature factor S_t allows for a decreasing load carrying capability of the coupling at elevated ambient temperatures
- The maximum torque capacity T_{Kmax} of the coupling shall be at least equal to the highest torque T_{max} encountered in operation
- The permissible continuous fatigue torque under reversed stresses T_{KW} of the coupling shall be at least equal to the highest fatigue torque under reversed stresses T_W encountered throughout the operating speed range while taking the temperature and frequency into account. The frequency factor S_f allows for the frequency dependence of the permissible continuous fatigue torque under reversed stresses T_{KW(10Hz)} at the operating frequency f_x

$$T_{AN} [Nm] = 9550 \frac{P_{AN} [kW]}{n_{AN} [rpm]}$$

$$T_{KN} \geq T_{AN} \cdot S_t$$

	60 °C	70 °C	80 °C	90 °C
S _t	1.0	1.2	1.4	1.6

$$T_{Kmax} \geq T_{max}$$

$$T_{KW(10Hz)} \geq T_W \cdot S_t \cdot S_f$$

$$S_f = \sqrt{\frac{f_x}{10}}$$

The dimensioning of the coupling should be checked for the permissible coupling load by means of a torsional vibration analysis which will be conducted by us on request.

For demanding applications in terms of torsional vibration or drives with 1-3 cylinder diesel engines we recommend to use our highly torsionally flexible ARCUSAFLEX flywheel couplings.

Dimension tables

MULTI MONT OCTA standard designs with flanges to SAE J 620

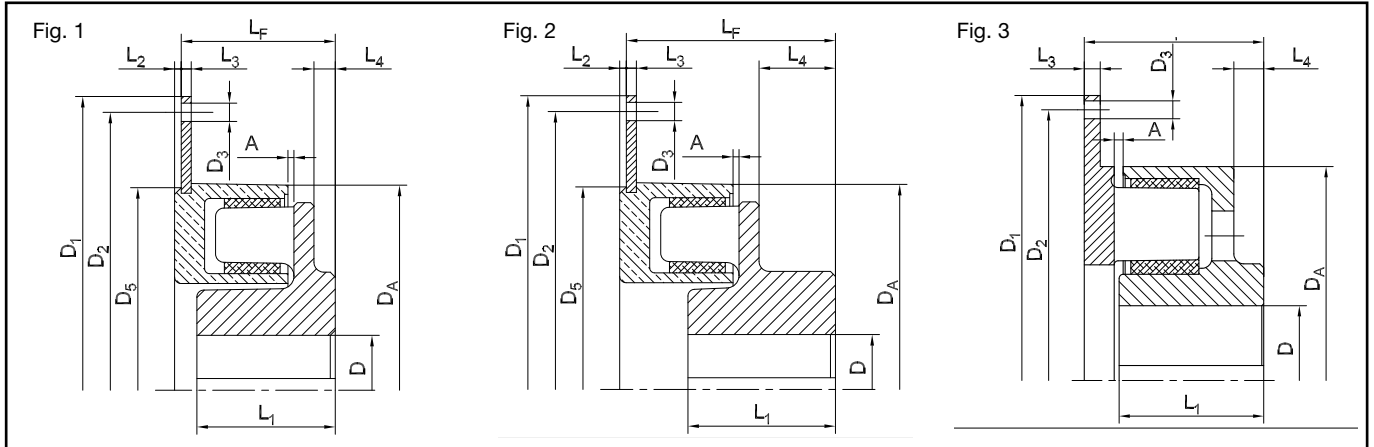

MULTI MONT OCTA Coupling size	Standard flanges							Standard hubs																	
	SAE size	D _A	D ₅	L ₂	L ₃	m kg	J ₁ kgm ²	Abb.	A	L _F	D		L ₁	L ₄	m kg	J ₂ kgm ²									
											pilot.	max.													
MMO-65 *) F2	6.5					1.6	0.012	1	5±1	58		55	45	10	3.2	0.007									
	7.5					2.1	0.016										60	60	25	3.9	0.008				
	8	170	188	4	6	2.5	0.023										73	60	96	87	5.4	0.009			
	10					3.6	0.047										135								
	11½					4.6	0.073																		
MMO-125 *) F2	8					3.1	0.033	1	6±1	58	unbores, precentered	60	60	-	4.6	0.014									
	10	194	213	4	6	4.1	0.055										73	65	75	14	5.8	0.015			
	11½					5.0	0.079										92.4	75	71	33	6.3	0.017			
	14					8.7	0.230										106.6	75	85	47	7.2	0.018			
																	150	75	85	75	7.7	0.020			
MMO-260 *) F2	11½					6.0	0.099	1	6±1	92.4	unbores, precentered	80	83	12	10.6	0.048									
	14	246	243	4	6	9.5	0.247										106.6	80	83	26	10.7	0.048			
																	135	85	90	69	12.0	0.051			
MMO-500 *) F2	11½					7.9	0.146	1	7±1.5	92.4	unbores, precentered	95	95	-	16.5	0.112									
	14	291	292	5	6	11.0	0.293										106.6	95	95	14	16.5	0.112			
																	150	95	147	57	22.6	0.128			
MMO-1100 *) F2	11½	358.5	-	-	10	19.0	0.510	1	8±2	92.4 ¹⁾	60	125	105	-	34.0	0.351									
	14	373	397	14	6	12.3	0.431										60	130	140	53	40.7	0.421			
	18	373	403	14	6	17.0	0.704										150 ¹⁾								
MMO-2000 *) F2	21	373	403	14	6	21.5	1.161	2																	
	18	429	-	-	16	46.1	1.780										3	9±2	180	70	150	145	30	63.0	1.410
	21					57.9	2.930																		

*) For the element version. see table „Technical details“ - 1) with SAE 11½ mounting length L_F 106.6 mm or 164 mm

Flanges and hubs of identical sizes can be combined for the respective coupling mounting length L_F. Other flange and length dimensions can be supplied on request.

Flange dimensions to SAE J 620

Nom. size	D ₁	D ₂	Z	D ₃
6,5	215.9	200	6	8,5
7,5	241.3	222.5	8	8,5
8	263.5	244.5	6	11
10	314.4	295.3	8	11
11½	352.4	333.4	8	11
14	466.7	438.2	8	13
16	517.5	489.0	8	13
18	571.5	542.9	6	17
21	673.1	641.4	12	17

Materials

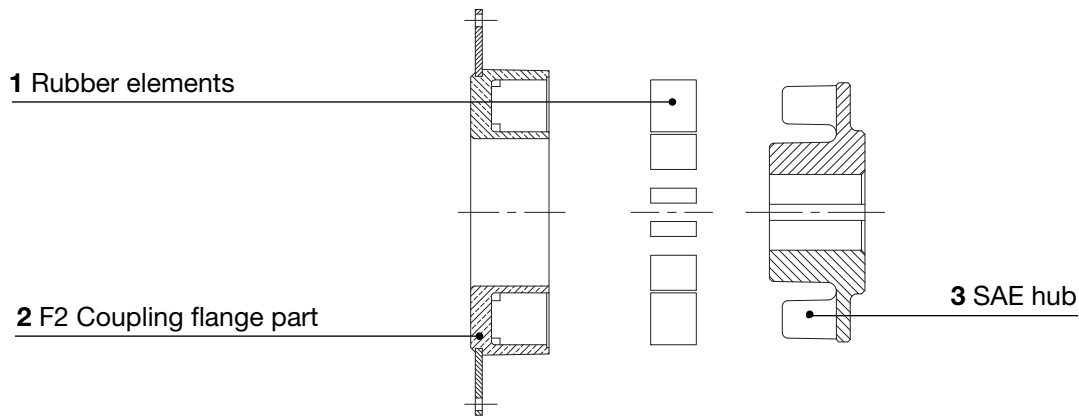

Item	Specification	Material
1	Rubber elements	Perbunan NBR (16 pieces = 1 set)
2	F2 Coupling flange part	Aluminium gravity die casting, steel plate St 37
3	SAE hub	Spherodial cast iron GGG 40

The flange for size MMO 2000 is made of GGG 40.

Ordering example: Coupling designation **MMO-125.NP.F2.14.92**

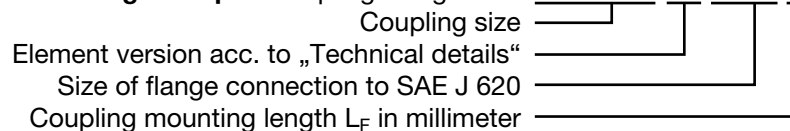

Please indicate bore and keyway dimensions for finished bores.

Mounting instructions

The permissible displacement tolerances¹⁾ should not be exceeded in order to ensure proper operation of the MULTI MONT OCTA coupling.

When used with flange mounted generators, the housing allows co-axial assembly of the coupling so that the only dimension to be checked is the distance A between the coupling flange and the hub flange.

Caution! In case of improper installation (too narrow) increased axial forces are generated.

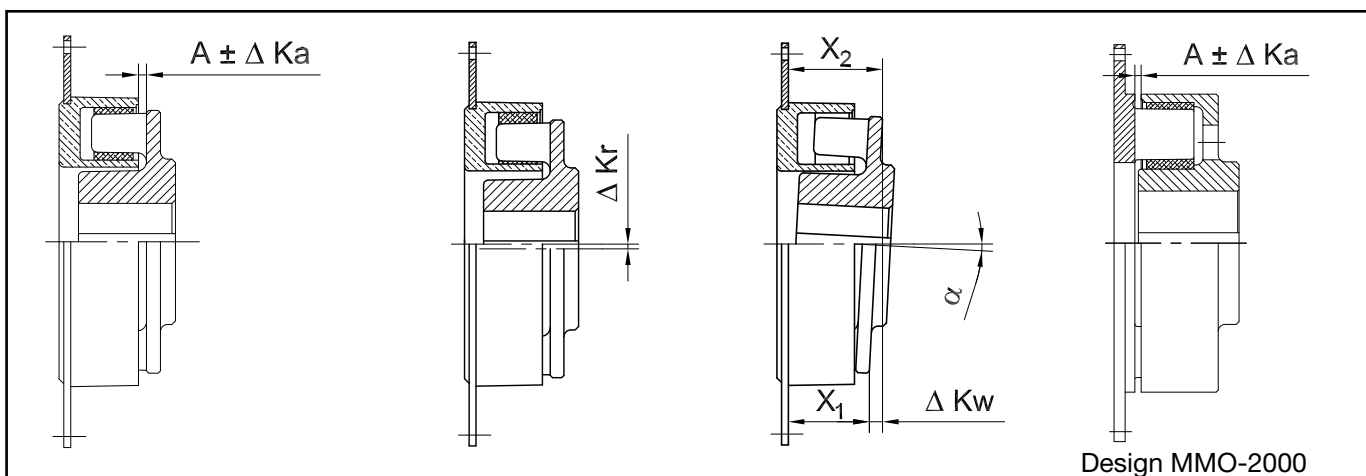

Coupling size	MMO-65	MMO-125	MMO-260	MMO-500	MMO-1100	MMO-2000
Distance $A \pm \Delta Ka$	5 ± 1	6 ± 1	6 ± 1	7 ± 1.5	8 ± 2	9 ± 2
Max. permissible radial displacement ΔKr	0.4	0.4	0.4	0.5	0.5	0.6
Max. permissible angular displacement ΔKw	0.4	0.5	0.6	0.7	0.8	1.0

¹⁾ Reference values for $n = 1500$ rpm

Typical installations

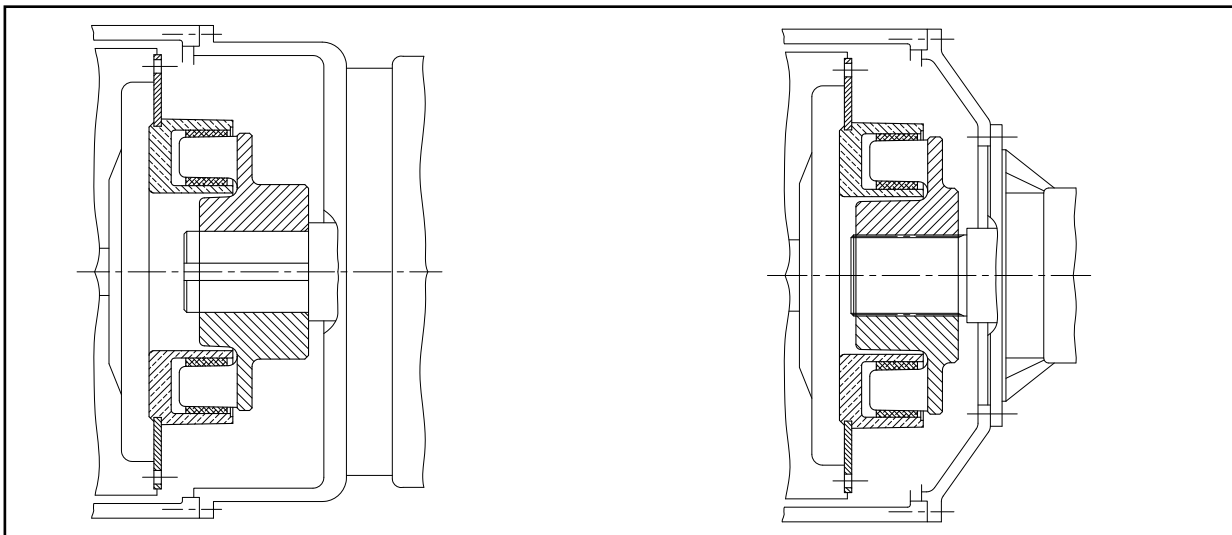

MULTI MONT OCTA-flywheel coupling
mounted between diesel engine and generator

MULTI MONT OCTA-flywheel coupling
mounted between diesel engine and
hydraulic pump

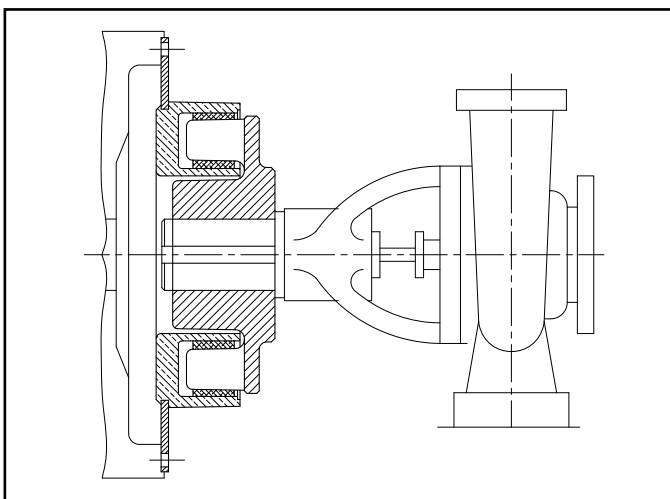

MULTI MONT OCTA-flywheel coupling
mounted between diesel engine and
centrifugal pump

MULTI MONT OCTA couplings are available for diesel and gas engines, for drive ratings up to 2100 kW at up to 1500 rpm. For higher drive ratings, please see our ARCUSAFLEX coupling catalogue.

Technical note

The technical data applies only to the complete coupling or the corresponding coupling elements. It is the customer's/user's responsibility to ensure there are no inadmissible loads acting on all the components. Especially existing connections, like bolt connections, have to be checked regarding the transmittable torque, if necessary other measures, e.g. additional reinforcement by pins, may be required. It is the customer's/user's responsibility to make sure the dimensioning of the shaft and keyed or other connection, e.g. shrinking or clamping connection, is correct.

REICH-KUPPLUNGEN have an extensive programme of couplings and coupling systems to cover nearly every drive configuration. Furthermore customized solutions can be developed and be manufactured also in small series or as prototypes. Calculation programmes are available for coupling selection and sizing. - Please challenge us!

Safety precautions

It is the customer's and user's responsibility to observe the national and international safety rules and laws. Proper safety devices must be provided for the coupling to prevent accidental contact.

Check all bolted connections for the correct tightening torque and fit after a short running period preferably after a test run.

Dipl.-Ing. Herwarth Reich GmbH
Vierhausstraße 53 • 44807 Bochum
P.O.Box 10 20 66 • 44720 Bochum
Telefon +49 (0) 234 9 59 16 - 0
Telefax +49 (0) 234 9 59 16 - 16
E-Mail: mail@reich-kupplungen.de
www.reich-kupplungen.de

