

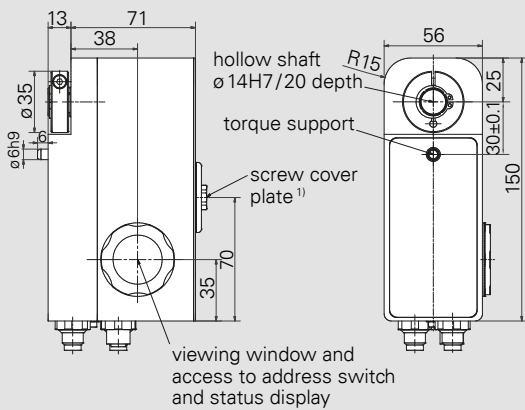

PSW 30x / 32x-14 (with hollow shaft)

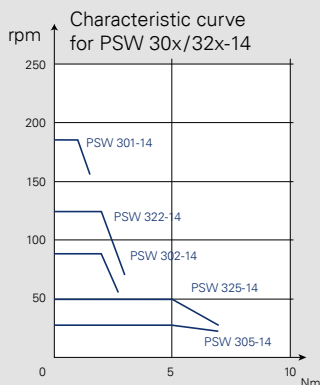

PSW 30x / 32x-14-V (with solid shaft)

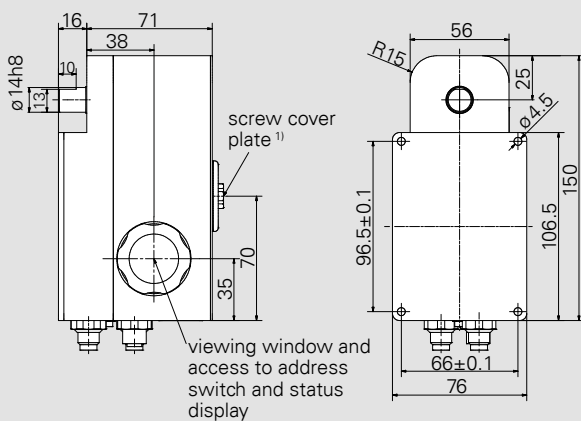

¹⁾ over a rotating manual adjustment shaft SW6/8 depth hex

Dimensions in mm.
For details of the connections please see also p. 55 and the instruction manual.

Product	Nominal torque	Self-holding torque	Nominal rated speed
PSW 301-14	1 Nm	0.5 Nm	180 rpm
PSW 302-14	2 Nm	1 Nm	90 rpm
PSW 305-14	5 Nm	2.5 Nm	35 rpm
PSW 322-14	2 Nm	1 Nm	125 rpm
PSW 325-14	5 Nm	2.5 Nm	50 rpm

Data interfaces

CANopen, PROFIBUS DP, DeviceNet, Modbus RTU, Sercos, EtherCAT, PROFINET, EtherNet/IP, POWERLINK, IO-Link

Duty cycle	20 % (basis time 600 s) at nominal torque
Mode of operation	S3
Supply voltage	24 VDC $\pm 10\%$ galvanically separated between control and motor and bus
Nominal current	PSW 30x: 2.4 A, PSW 32x: 3.1 A
Power consumption (control unit)	0.1 A
Positioning accuracy absolute measurement of position taken directly at the output shaft	0.9°
Positioning range	250 rotations not subject to mechanical limits
Shock resistance in accordance with IEC/DIN EN 60068-2-27	50g 11 ms
Vibration resistance in accordance with IEC/DIN EN 60068-2-6	10..55 Hz 1.5 mm/ 55..1 000 Hz 10g/ 10..2 000 Hz 5g
Output shaft	14 mm solid shaft or 14 mm hollow shaft with adjustable collar
Snap-on brake	optional (holding torque = nominal torque)
Maximum axial force	20 N
Maximum radial force	40 N
Ambient temperature	0..45 °C
Storage temperature	-10..70 °C
Protection class	IP68 at standstill ¹⁾ , IP66 during rotation (tested with water) ¹⁾
Material	stainless steel
Weight	1 200 g
Certificates	CE, optional: NRTL

¹⁾ welded V2A housing, output shaft sealed with quad-ring

ORDER KEY PSE/PSS/PSW 3 SERIES



	A	B	C	D	E	F	G	
	Design	Type	Bus communication (see p.7)	Connections	Brake (see p.11)	Certification	IP protection class	
Positioning System Efficient (see p.22-28)	PSE	30x-8/-14 (V)	CA: CANopen DP: PROFIBUS DP DN: DeviceNet ²⁾ MB: Modbus RTU ²⁾	O: Standard T: Standard with jog keys ³⁾⁴⁾	0: without M: with ⁶⁾	0: CE N: NRTL + CE S: STO + CE without test pulses ⁷⁾	54: IP 54 ⁸⁾ 65: IP 65 ⁹⁾ 68: IP 68 ¹⁰⁾	
Positioning System Stainless (see p.29-33)		PSS	32x-14 (V) 33x-14 (V)	SE: Sercos EC: EtherCAT PN: PROFINET EI: EtherNet/IP PL: POWERLINK IO: IO-Link		Y: Plug-in, Y-coded ⁵⁾ Z: Plug-in, Y-coded, with jog keys ³⁾⁵⁾		T: STO + CE with test pulses ⁷⁾ Y: STO + NRTL without test pulses ⁷⁾ Z: STO + NRTL with test pulses ⁷⁾
Positioning System Washable (see p.34-38)		PSW	34xx-14 ¹⁾					

¹⁾ only for PSE

²⁾ not for PSE34xx

³⁾ not for PSE31x

⁴⁾ always via an extra connector plug, not for IO-Link or PSW

⁵⁾ not for PSE34xx

⁶⁾ only 14 mm output shafts

⁷⁾ only for IP65, not for PSE34xx, only for EtherCAT, PROFINET, EtherNet/IP, only on request

⁸⁾ only for PSE, PSE34xx only IP65
⁹⁾ for PSS, for PSE 30x/31x/32x/33x on request
¹⁰⁾ only for PSW

Standard equipment (connections)

- always provided with 3 plugs/sockets (not for IO-Link or Y-encoded connector)
- address switches always provided (also IE-buses, not for IO-Link)

For further information on connections and address settings see also "bus communication details" on p.55.

Form/Type	Torque	Output shaft
horizontal 30	x = 1 Nm x = 2 Nm	8 = 8 mm hollow shaft
vertical 31	x = 5 Nm	14 = 14 mm hollow shaft
horizontal 32	x = 10 Nm	8V = 8 mm solid shaft
vertical 33	x = 18 Nm x = 25 Nm ¹¹⁾	14V = 14 mm solid shaft

¹¹⁾ only for PSE

Examples of orders provided below.

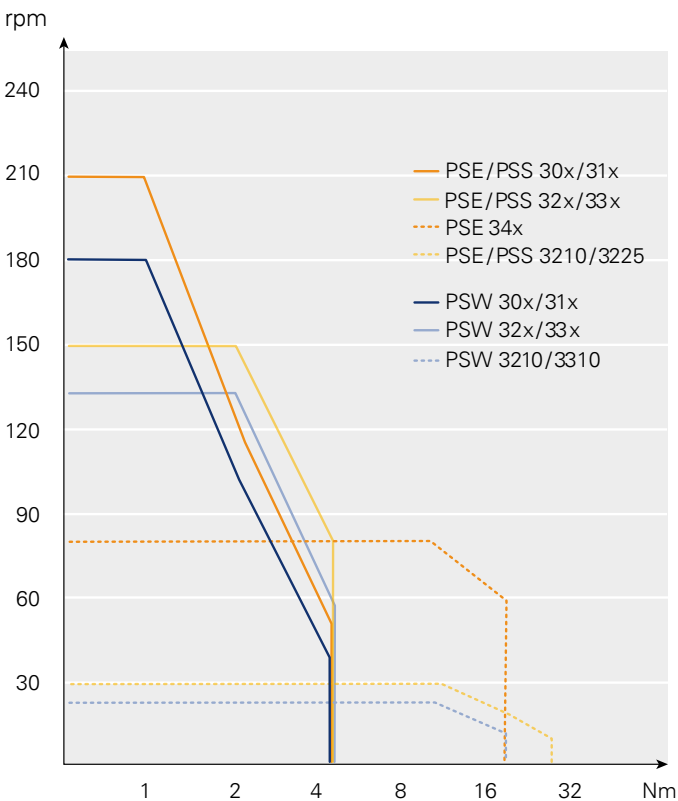

Nominal torque – nominal speed combinations

TORQUES AND SPEEDS

Example 1

You require the protection class IP54 and a maximum torque of 2Nm. The speed should be greater than 100rpm. An 8mm hollow shaft and longitudinal construction meet the requirements of your application. You wish to use EtherNet/IP as the bus and connect the PSE to the control unit using a hybrid connector and hub. You do not require an additional holding brake in your application.

→ PSE 312-8-EI-Y-0-0

Example 2

IP68, max. 3Nm, > 100 rpm, horizontal construction, 14 mm solid circular shaft, IO-Link via a connector, with brake.

→ PSW 325-14V-IO-0-M-0

ACCESSORIES PSE/PSS/PSW 3 SERIES

The connectors shown here can be used for all 3 types of device (PSE/PSS/PSW). This ensures that the PSE (IP54) and PSS (IP65) comply with the IP protection classes. We will also be pleased to help you find a suitable mating connector for the PSW (IP68) if necessary – just ask us!

Bus communication	Power supply + databus connector (2x) (for option 0) ¹⁾	Power supply + databus (2x) + jog key connector (for option T, not for PSW) ¹⁾²⁾	Cable and connectors for 1-connector solution ³⁾ (for option Y or IO-Link) ¹⁾
CANopen ⁴⁾	 <p>Connector set: Order no. 9601.0060</p>	 <p>Connector set: Order no. 9601.0062</p>	 <p>5 m: Order no. 9601.0245 10 m: Order no. 9601.0233 20 m: Order no. 9601.0234</p>
PROFIBUS DP			
Modbus RTU			
DeviceNet	 <p>Connector set: Order no. 9601.0088</p>	 <p>Connector set: Order no. 9601.0090</p>	
Sercos	 <p>Connector set: Order no. 9601.0112</p>	 <p>Connector set: Order no. 9601.0317</p>	<p>5 m: Order no. 9601.0240 10 m: Order no. 9601.0244</p> <p>Hub on request</p>
EtherCAT			
PROFINET			
EtherNet/IP			
POWERLINK			
IO-Link ³⁾	-	-	 <p>Connector: Order no. 9601.0107³⁾</p>

¹⁾ see under "D" in the order key ²⁾ jog key box order no. 9601.0241 ³⁾ power supply and bus via one cable, without second data bus connector

⁴⁾ standard connector coding: A- or B- coding, other codings possible on request possible on request

FURTHER ACCESSORIES



Jog key box
(for Option T, not for PSW)

Order no. 9601.0241



Screw cap to cover the
second bus connection
(for PSS/PSW)

Order no. 9601.0176

SOFTWARE

Take advantage of our functional modules or description files for the various buses. You can download the files on our website:

www.halstrup-walcher.de/en/software

