

Motion Control Systems

V2.5, 4-Quadrant PWM with RS232 or CANopen interface

67 mNm
32 W

3242 ... BX4 Cx

Values at 22°C and nominal voltage	3242 G	024BX4 Cx	
Power supply electronic	U_B/U_{EL}	12 ... 30	V DC
Power supply motor ¹⁾	$-/U_B$	0 ... 30	V DC
Nominal voltage for motor	U_N	24	V
No-load speed (at U_N)	n_0	5 100	min ⁻¹
Peak torque (S2 operation for max. 5s)	M_{max}	134	mNm
Torque constant	k_M	42,1	mNm/A
PWM switching frequency	f_{PWM}	78	kHz
Efficiency electronic	η	95	%
Standby current for electronic (at $U_B=24V$)	I_{el}	0,055	A
Speed range (up to 30V)		1 ... 6 500	min ⁻¹
Shaft bearings	ball bearings, preloaded		
Shaft load max.:			
– with shaft diameter	5		mm
– radial at 3 000 min ⁻¹ (5 mm from mounting flange)	50		N
– axial at 3 000 min ⁻¹ (push / pull)	5		N
– axial at standstill (push / pull)	50		N
Shaft play:			
– radial	≤ 0,015		mm
– axial	= 0		mm
Operating temperature range	-40 ... +100		°C
Housing material	motor: stainless steel; controller housing: zinc, black anodized		
Mass	370		g

¹⁾ Only available for option 2993 (separate power supply)

Rated values for continuous operation

Rated torque	M_N	67	mNm
Rated current (thermal limit)	I_N	1,65	A
Rated speed	n_N	3 300	min ⁻¹

Interface / range of functions

	... CS	... CO
Configuration from Motion Manager 5.0	RS232	CANopen
Fieldbus	RS232	CANopen
Operating modes (CS)	Position/speed/torque control via interface or analogue set value specification. Operation as servo amplifier in voltage controller mode.	
Operating modes (CO)	Profile Position Mode (PP), Profile Velocity Mode (PV), Homing Mode.	
Speed range	see motor diagram	
Application programs, (CS)	Command sequences from movement and control commands can be placed directly into the controller as user programs.	
Additional functions	Enables stand-alone operation without a connected communication interface. Overload protection for electronics and motor, self-protection from overheating, over-voltage protection in generator mode.	

Note:

The display shows the range of possible operation points of the drives at a given ambient temperature of 22°C.

The diagram indicates the recommended speed in relation to the available torque at the output shaft.

It includes the assembly on a plastic- as well as on a metal flange (assembly method: IM B 5).

The nominal voltage linear slope describes the maximal achievable operating points at nominal voltage. Any points of operation above this linear slope will require a supply voltage $U_{mot} > U_N$.

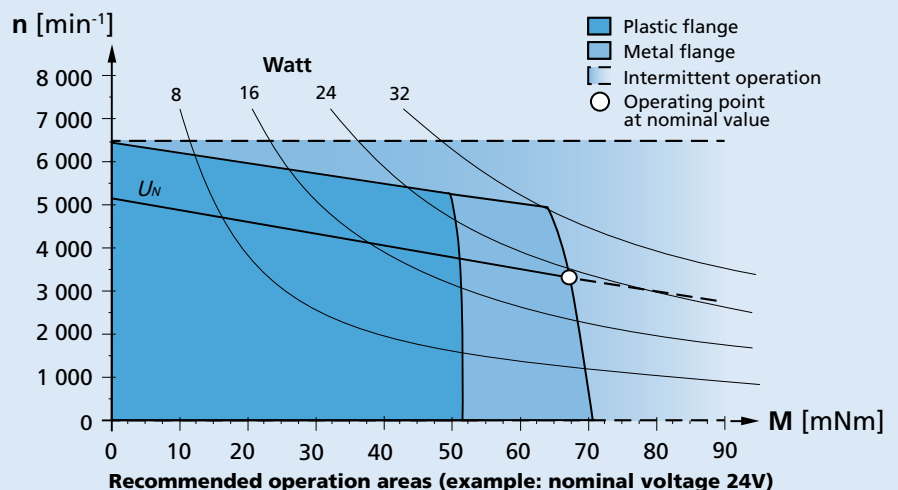

Dimensional drawing

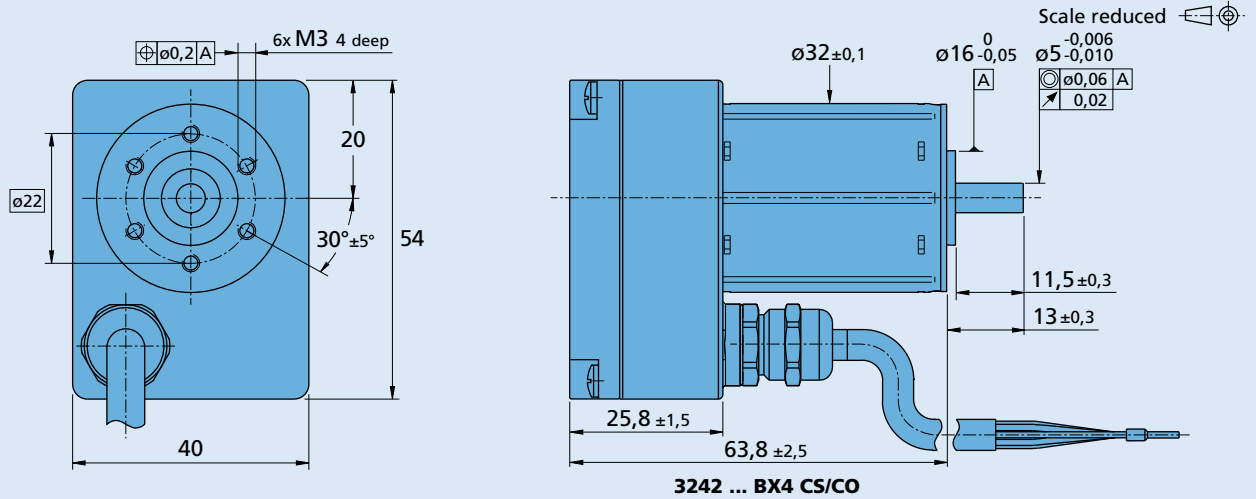

Option, cable and connection information

Example product designation: **3242G024BX4CS-2993**

Option	Type	Description	Connection	
2993	Supply	Separate voltage supply for motor and electronics	Wires	Function
			blue	GND
			pink	U_B
			brown	Analog input
			white	Fault output
			grey	Analog GND
			yellow	RS232 RXD / CAN_L
			green	RS232 TXD / CAN_H
			red	Connection No. 3
			Standard cable	
			PVC-cable, 8-conductors AWG 24, length 1 meter	
			Caution:	
			Connect motor supply terminals to the correct polarity. Electronics are protected against polarity reversal by an internal fuse. In case of damage, this internal fuse can only be replaced at the factory.	
			Note: For details on the connection assignment, see device manual MCS.	

Product combination

Precision Gearheads / Lead Screws	Encoders	Drive Electronics	Cables / Accessories
32A 32ALN 32GPT 32/3 32/3R 38A 38/1 38/1 S 38/2 38/2 S 42GPT		Integrated	To view our large range of accessory parts, please refer to the "Accessories" chapter.