

BEULCO[®]

The Plug-In Connector.

BEULCONNECT.

For water and gas.

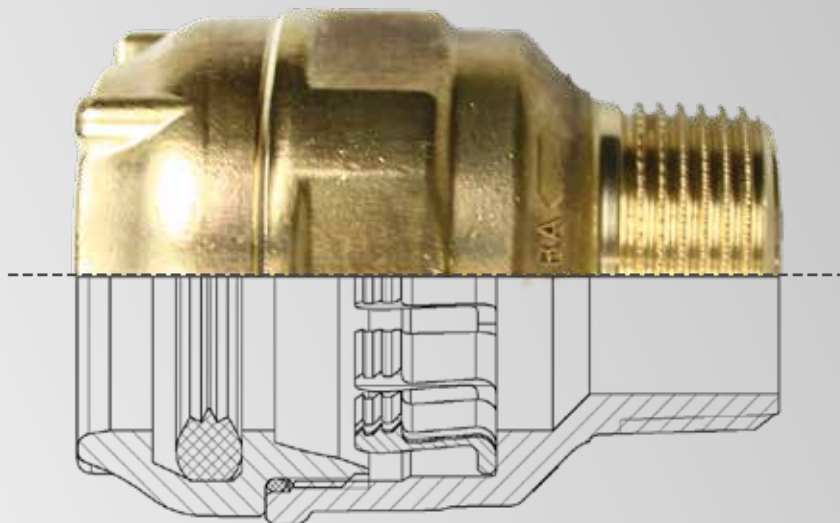

■ made
■ in
■ Germany

A11

2018.1

**MINIMUM
EFFORT.**

**MAXIMUM
EFFECT.**

The Plug-In Connector - A11

For Drinking Water and Water or Gas.

The BEULCONNECT plug-in connector is constructed in such a way that it clamps the pipe by a gentle plug-in technology. It is leakproof for a lifetime and enables a trouble-free and stress-free installation. The plug-in connector guarantees special safety: The pipe only has to be plugged-in – a control can be omitted (e.g. whether a pressing nut has been correctly tightened).

Dimensions:

- for plastic pipes: \varnothing 25 mm to \varnothing 63 mm

Nominal pressure:

- PE 80 (PN 12,5), PE 100 (PN 16), PE-Xa (PN 12,5)

Type of pipes:

- PE 80, PE 100
- PE-Xa
- PVC (with brass clamping ring for PVC-pipes)

Applications:

- Drinking water up to 40 °C
- Cold and warm water up to 40 °C
- Utilisation of rainwater
- Gas (by use of insert pipe)

Connector (for water) tested acc. to:

- DIN 8076/DVGW GW 335-B4 DN 20 - DN 50 Water
- Kiwa BRL-K 17105/01 DN 20 - DN 50 Water
- ACS /13ACC LY190 Hygiene Water

Connector (for gas) tested acc. to:

- DVGW G5600-1 DN 25 - DN 50 Gas
- ARGB-KVBG DN 25 - DN 50 Gas



kiwa

You can find the latest certificates here:

www.beulco.de/Zertifikate



Material

Our connectors are made of thermally unstressed brass and Ecobrass. Ecobrass is a lead-free alloy, qualified for the use in drinking water areas according to European Drinking Water Directive 98/837EC. The material meets the hygienic and legal requirements for drinking water. The reliable brass is characterized by dezincification resistance and high durability.

Sealing

For the application in the field of drinking water the connector has the tested EPDM profile gasket which reliably seals minor damages on the surface. The plug-in connectors for the application in the fields of water and gas additionally have a special o-ring. The sealing and clamping functions are separated and independent which makes the connector extraordinarily safe.

Construction

The material-friendly connecting technique enables that the pipe is only stressed as the relations of pressure and torsion demand. Premature wear due to overstressing of material and subsequent troubles can be excluded. The metal clamping claw enables a torsion-free assembly by its positioning. The connector can easily be dismantled – all components can be reused without problems.

For the application in the field of gas the connector has an additional insert pipe to stabilise the pipe.



Plug-in connector for drinking water and water without insert pipe



plug-in connector for gas with loose insert pipe

Installation Instruction BEULCONNECT - A11

Plug-in connector



Step 1
Cut the pipe at a right angle at the previously affixed marking.



Step 2
Chamfer the pipe up to the inner diameter (e.g. with chamfering tool model 8880, item 124527).



Step 3
Mark the insertion depth on the pipe.

(For the use in gas sector the insert pipe has to be pressed in up to the limit stop)



Step 4
Insert the pipe up to the marking.



The insertion depth of the pipe is made visible by a marking on the fitting body.

Note:

- For oval pipes we recommend the use of insert pipes in order to guarantee the optimal holding and sealing functions.
- Corrosion protection according to DIN 50929 is necessary on site in the field of buried pipelining.

Repair Coupling



Step 1
Cut the pipe at a right angle at the previously affixed marking.



Step 2
Chamfer the pipe up to the inner diameter (e.g. with chamfering tool model 8880, item 124527).



Step 3
Mark the insertion depth on both pipes.



Step 4
Insert the pipe on the first side up to the marking.



Step 5
Insert the pipe on the second side up to the marking

Repair Connector



Step 1
Cut the pipe at a right angle at the previously affixed marking.



Step 2
Chamfer the pipe up to the inner diameter (e.g. with chamfering tool model 8880, item 124527).



Step 3
Mark the insertion depth on the pipe.



Step 4
Bolt the repair connector with the fitting (Mind a suitable sealing!).



Step 5
Push the repair connector onto the pipe up to the marking.

Note: Step 4 and 5 can be interchanged depending on the situation.

! We recommend to extend the repair couplings to the maximum length during assembly and to shorten the pipe accordingly. If this is not possible, fixed points must be placed in front of and behind the connector.

Plug-In Connector - Repair Program BEULCONNECT - A11

For the safe bridging of pipe damages the BEULCONNECT repair couplings and connectors offer the optimal solution. The repair assortment is designed in a way that due to the material-friendly smart grip technology the pipe is only stressed as the pressure situation requires.

Repair Coupling

The BEULCO repair couplings are equipped with two equal plastic pipe connections and ensure the ideal bridging of pipe damages. The plug-in technology guarantees a fast and safe installation.

Model 1106

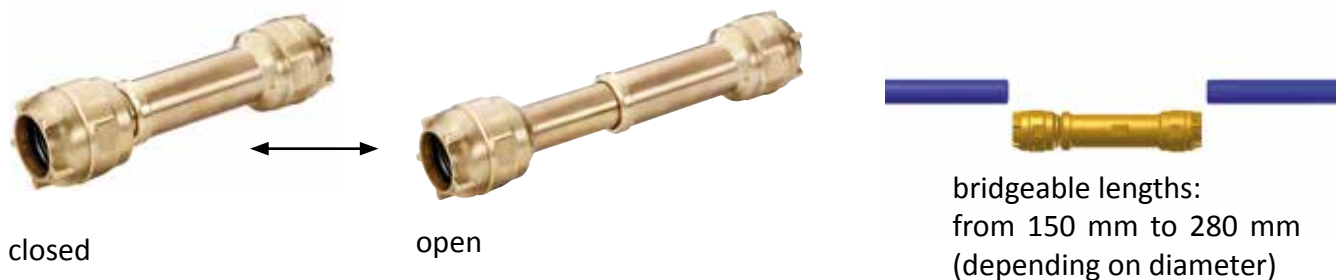

Repair Connector

The BEULCO repair connectors have a male thread. The plug-in technology ensures a fast and safe installation.

Model 1102

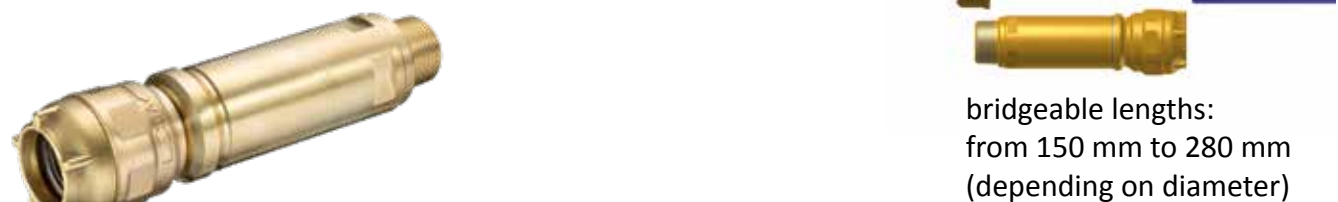

Reduction Set

With the reduction set, plug-in connectors with dimensions 32, 40, 50 and 63mm can be reduced by one dimension. Therefore, the conical nut and the clamping ring have to be replaced.

Products for **drinking water** and **water** are on pages **8 - 12**.

Products for **gas** are on pages **13 - 17**.

APPLICATION	D	● = Drinking water
	W	● = Water
	G	● = Gas

Overview

Image	Description	Page	Image	Description	Page	Image	Description	Page
	Connector male thread Model 1101 ● ●	8		T-piece 3 x plastic pipe connection Model 1118 ● ●	10		Coupling with insert pipe Model G1105 ●	14
	Connector male thread reduced Model 11011 ● ●	8		Repair coupling Model 1106 ● ●	11		Elbow 90° male thread with insert pipe Model G1130 ●	14
	Connector male thread increased Model 11012 ● ●	8		Repair connector male thread Model 1102 ● ●	11		Elbow 90° male thread reduced with insert pipe Model G11300 ●	14
	Connector female thread Model 11110 ● ●	9		Gate valve Model 11700 ● ●	12		Elbow coupling 90° with insert pipe Model G11301 ●	14
	Coupling Model 1105 ● ●	9		Gate valve Model 8350 ● ●	12		T-piece with insert pipe Model G1118 ●	15
	Elbow 90° male thread Model 1130 ● ●	9		Reduction set Model 1155 ● ●	12		Connector male thread for pressure tap valve Model G11500 ●	15
	Elbow 90° male thread reduced Model 11300 ● ●	10		Connector male thread with insert pipe Model G1101 ●	13		Elbow adapter for tapping valve Model G11600 ●	15
	Elbow 90° male thread increased Model 11302 ● ●	10		Connector male thread reduced with insert pipe Model G11011 ●	13			
	Elbow coupling 90° Model 11301 ● ●	10		Connector female thread with insert pipe Model G11110 ●	13			

Accessories

	Clamping ring for PE pipes Model 1191 ● ● ●	16		Insert pipe Model 8900 ● ● ●	16		Sealing band „Loctite“ Model 9998	17
	Clamping ring for PVC pipes Model 1194 ● ●	16		Silicone Lubricant Berusil Model 8870	17			



CONNECTOR, MALE THREAD

Model 1101

with plastic pipe connection and male thread

Item may differ from the picture.

plastic pipe dimension (mm)	thread	D	W	pkg. unit	EAN no. 4027848-
25	3/4"	●	●	10	339143
32	1"	●	●	10	339150
40	1 1/4"	●	●	5	339167
50	1 1/2"	●	●	5	339174
63	2"	●	●	2	339181



CONNECTOR, REDUCED MALE THREAD

Model 11011

with plastic pipe connection and reduced male thread

Item may differ from the picture.

plastic pipe dimension (mm)	thread	D	W	pkg. unit	EAN no. 4027848-
25	1/2"	●	●	1	349890
32	3/4"	●	●	10	341344
40	1"	●	●	5	341375
50	1"	●	●	2	354245
50	1 1/4"	●	●	5	341405



CONNECTOR, INCREASED MALE THREAD

Model 11012

with plastic pipe connection and increased male thread

Item may differ from the picture.

plastic pipe dimension (mm)	thread	D	W	pkg. unit	EAN no. 4027848-
32	1 1/4"	●	●	5	354146
32	1 1/2"	●	●	5	354160
40	1 1/2"	●	●	5	354184

APPLICATION	D	● = Drinking water
	W	● = Water
	G	● = Gas



CONNECTOR, FEMALE THREAD
Model 11110

with plastic pipe connection and female thread

Item may differ from the picture.

plastic pipe dimension (mm)	thread	D	W	pkg. unit	EAN no. 4027848-
25	3/4"	●	●	10	342488
32	1"	●	●	10	342518
40	1 1/4"	●	●	5	342549
50	1 1/2"	●	●	2	342570
63	2"	●	●	2	342600



COUPLING
Model 1105

with 2 equal plastic pipe connections

Item may differ from the picture.

plastic pipe dimension (mm)	D	W	pkg. unit	EAN no. 4027848-
25	●	●	5	341184
32	●	●	5	340842
40	●	●	2	341214
50	●	●	2	341153
63	●	●	1	341245



ELBOW 90°, MALE THREAD
Model 1130

with plastic pipe connection and male thread

Item may differ from the picture.

plastic pipe dimension (mm)	thread	D	W	pkg. unit	EAN no. 4027848-
25	3/4"	●	●	5	341511
32	1"	●	●	5	341542
40	1 1/4"	●	●	5	341573
50	1 1/2"	●	●	2	341603



ELBOW 90°, REDUCED MALE THREAD
Model 11300

with plastic pipe connection and reduced male thread

Item may differ from the picture.

plastic pipe dimension (mm)	thread	D	W	pkg. unit	EAN no. 4027848-
40	1"	●	●	5	344475
50	1"	●	●	2	354214
50	1 1/4"	●	●	2	344512



ELBOW 90°, INCREASED MALE THREAD
Model 11302

with plastic pipe connection and increased male thread

Item may differ from the picture.

plastic pipe dimension (mm)	thread	D	W	pkg. unit	EAN no. 4027848-
32	1 1/2"	●	●	5	354337
40	1 1/2"	●	●	5	354306



ELBOW COUPLING
Model 11301

with 2 equal plastic pipe connections

Item may differ from the picture.

plastic pipe dimension (mm)	D	W	pkg. unit	EAN no. 4027848-
25	●	●	5	343430
32	●	●	5	343461
40	●	●	2	343492
50	●	●	2	343522



T-PIECE
Model 1118

with 3 equal plastic pipe connections

Item may differ from the picture.

plastic pipe dimension (mm)	D	W	pkg. unit	EAN no. 4027848-
25	●	●	5	343652
40	●	●	1	343713
50	●	●	1	343744
63	●	●	1	343775

APPLICATION	D	● = Drinking water
	W	● = Water
	G	● = Gas

REPAIR COUPLING

Model 1106



with 2 equal plastic pipe connections for bridging pipe damages

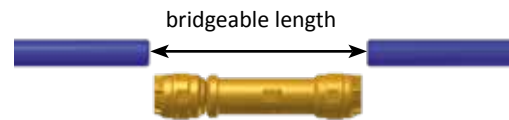

Item may differ from the picture.

We recommend to extend the repair couplings to the maximum length during assembly and to shorten the pipe accordingly. If this is not possible, benchmarks must be placed in front of and behind the connector.

plastic pipe dimension (mm)	bridgeable length (min.-max. mm)	D	W	pkg. unit	EAN no. 4027848-
25	150 - 180	●	●	1	351220
32	170 - 200	●	●	1	351152
40	190 - 220	●	●	1	352098
50	210 - 240	●	●	1	352494

REPAIR CONNECTOR, MALE THREAD

Model 1102



with plastic pipe connection and male thread for bridging pipe damages

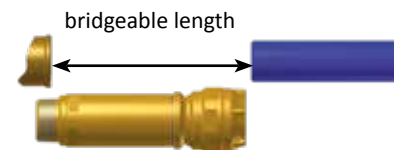

Item may differ from the picture.

We recommend to extend the repair couplings to the maximum length during assembly and to shorten the pipe accordingly. If this is not possible, benchmarks must be placed in front of and behind the connector.

plastic pipe dimension (mm)	thread	bridgeable length (min.-max. mm)	D	W	pkg. unit	EAN no. 4027848-
25	3/4"	150 - 180	●	●	1	352142
32	1"	170 - 200	●	●	1	352128
40	1 1/2"	210 - 240	●	●	1	365845
50	1 1/2"	210 - 240	●	●	1	352517

In order to cover each case of application we can provide the BEULCO repair connector with plug-in technology also with 1 1/2" thread for pipes with 40 mm diameter.

When changing tapping sleeves it is sometimes necessary to cut a piece of the connection conduit so that the distance of pipe to new tapping sleeves will grow. For the conventional connection the pipe is now too short. In this case the BEULCO repair connector enables an individual length adjusting, as the distances from 210 mm up to 240 mm can safely be bridged.



GATE VALVE
Model 11700

Item may differ from the picture.

plastic pipe dimension (mm)	thread	D	W	pkg. unit	EAN no. 4027848-
25 x 1	1/2"	●	●	1	353507



GATE VALVE
Model 8350

with plug-in connector BEULCONNECT on both sides for plastic pipe connection

Item may differ from the picture.

plastic pipe dimension (mm)	thread	D	W	pkg. unit	EAN no. 4027848-
32	1"	●	●	1	368037
40	1 1/4"	●	●	1	368044
50	1 1/2"	●	●	1	368051
63	2"	●	●	1	368068



REDUCTION SET
Model 1155

consisting of: conical nut, clamping ring, guide ring and lip seal

Item may differ from the picture.

reduction from	D	W	pkg. unit	EAN no. 4027848-
32 up to 25 mm	●	●	1	350278
40 up to 32 mm	●	●	1	350285
50 up to 40 mm	●	●	1	350292
63 up to 50 mm	●	●	1	350308

APPLICATION	D	● = Drinking water
	W	● = Water
	G	● = Gas



CONNECTOR, MALE THREAD
Model G1101

with plastic pipe connection and male thread
with insert pipe

Item may differ from the picture.

plastic pipe dimension (mm)	thread	G	pkg. unit	EAN no. 4027848-
32 x 2,9	1"	●	2	343232
40 x 3,7	1 1/4"	●	2	343249
50 x 4,6	1 1/2"	●	2	343256
63 x 5,8	2"	●	2	343263



CONNECTOR, REDUCED MALE THREAD
Model G11011

with plastic pipe connection and reduced male thread
with insert pipe

Item may differ from the picture.

plastic pipe dimension (mm)	thread	G	pkg. unit	EAN no. 4027848-
32 x 2,9	3/4"	●	10	343317
40 x 3,7	1"	●	5	343324
50 x 4,6	1 1/4"	●	5	343331



CONNECTOR, FEMALE THREAD
Model G11110

with plastic pipe connection and female thread
with insert pipe

Item may differ from the picture.

plastic pipe dimension (mm)	thread	G	pkg. unit	EAN no. 4027848-
32 x 2,9	1"	●	5	343829
40 x 3,7	1 1/4"	●	5	343836
50 x 4,6	1 1/2"	●	2	343843
63 x 5,8	2"	●	2	343850



COUPLING

Model G1105

with 2 equal plastic pipe connections
with insert pipe

Item may differ from the picture.

plastic pipe dimension (mm)	G	pkg. unit	EAN no. 4027848-
32 x 2,9	●	2	343270
40 x 3,7	●	2	343287
50 x 4,6	●	2	343294
63 x 5,8	●	1	343300



ELBOW 90°, MALE THREAD

Model G1130

with plastic pipe connection and male thread
with insert pipe

Item may differ from the picture.

plastic pipe dimension (mm)	thread	G	pkg. unit	EAN no. 4027848-
32 x 2,9	1"	●	5	343348
40 x 3,7	1 1/4"	●	5	343355
50 x 4,6	1 1/2"	●	2	343362
63 x 5,8	2"	●	1	343379



ELBOW 90°, REDUCED MALE THREAD

Model G11300

with plastic pipe connection and reduced male thread
with insert pipe

Item may differ from the picture.

plastic pipe dimension (mm)	thread	G	pkg. unit	EAN no. 4027848-
40 x 3,7	1"	●	5	344482
50 x 4,6	1 1/4"	●	2	344529

APPLICATION	D ● = Drinking water
	W ● = Water
	G ● = Gas



ELBOW COUPLING
Model G11301

with 2 equal plastic pipe connections
with insert pipe

Item may differ from the picture.

plastic pipe dimension (mm)	G	pkg. unit	EAN no. 4027848-
32 x 2,9	●	5	343560
40 x 3,7	●	2	343577
50 x 4,6	●	2	343584
63 x 5,8	●	1	343591



T-PIECE
Model G1118

with 3 equal plastic pipe connections
with insert pipe

Item may differ from the picture.

plastic pipe dimension (mm)	G	pkg. unit	EAN no. 4027848-
32 x 2,9	●	2	343782
40 x 3,7	●	1	343799
50 x 4,6	●	1	343805



CONNECTOR
Model G11500

for pression tapping valve
with quick plug-in connection with insert pipe
for plastic pipes and pipe male thread G 2 A

Item may differ from the picture.

plastic pipe dimension (mm)	thread	G	pkg. unit	EAN no. 4027848-
32 x 2.9	2"	●	1	344949
40 x 3,7	2"	●	1	344987
40 x 3,7	1 1/2"	●	1	346608



ELBOW ADAPTER
Model G11600

for tapping valve, freely turnable
with plug-in connection with insert pipe
for plastic pipe, union nut Tr 63 x 5

Item may differ from the picture.

plastic pipe dimension (mm)	thread	G	pkg. unit	EAN no. 4027848-
32 x 2.9	2"	●	1	345168
40 x 3,7	2"	●	1	345199



CLAMPING RING
Model 1191

for PE pipes

Item may differ from the picture.

plastic pipe dimension (mm)	D	W	G	pkg. unit	EAN no. 4027848-
25	●	●	●	1	338900
32	●	●	●	1	338917
40	●	●	●	1	338924
50	●	●	●	1	338931
63	●	●	●	1	338948



CLAMPING RING
Model 1194

for PVC pipes

Item may differ from the picture.

plastic pipe dimension (mm)	D	W	pkg. unit	EAN no. 4027848-
25	●	●	1	354085
32	●	●	1	354092
40	●	●	1	354108
50	●	●	1	354115
63	●	●	1	354122

APPLICATION	D	● = Drinking water
	W	● = Water
	G	● = Gas



INSERT PIPE Model 8900

For oval pipes we recommend the use of insert pipes in order to guarantee the optimal holding and sealing functions.

Item may differ from the picture.

plastic pipe dimension (mm)	D	W	G	pkg. unit	EAN no. 4027848-
32 x 3	●	●	●	1	272198
40 x 3,7	●	●	●	1	249701
50 x 4,6	●	●	●	1	249718
63 x 5,8	●	●	●	1	249725



SILICONE LUBRICANT BERUSIL Model 8870

Item may differ from the picture.

	pkg. unit	EAN no. 4027848-
50 ml dosing bottle	1	202225



SEALING BAND "LOCTITE" Model 9998

Not hardening thread sealing to seal conical/ cylindrical threads up to 6".
Reversing the thread is possible.
Temperature stability up to 130° C.
DVGW registration no. DV-5142AU0166.
Recommendation of KTW is available.

Item may differ from the picture.

	pkg. unit	EAN no. 4027848-
150 m per roll	1	218318

Notes

